

STÖRK

sampling solutions



STÖRK RAIL



STÖRK COMPACT



STÖRK PRO





STORK
sampling solutions

DV GROUP

SINCE 1987 WE TAKE CARE OF YOUR SAMPLES

DV is an Italian company operating since 1982 in the field of water-purification plants, belt and spiral transporters. In the 1987 we started the production of the grain sampler. In a few years time we have become the italian leader of this product. Our headquarters are in the town of Pordenone in the northeast of Italy. We believe in embracing new technologies while respecting the natural environment, to offer a range of products and services to satisfy the needs of all our customers. Our machinery is developed using the very best raw materials and up-to-date technology, with attention paid to every detail. We aim to offer long-term reliability and guarantee a fast and efficient assistance network.



**MAIN ADVANTAGES
OF AUTOMATIC
SAMPLING**

**AN UNSUITABLE
SAMPLE MAKES
THE ANALYSIS
MEANINGLESS**



1

REPRESENTATIVE
AND HOMOGENEOUS
SAMPLE

2

STRONG FRAME
LONG TERM
RESISTANCE

3

POWERFUL 2,2 KW
SIDE CHANNEL AIR
BLOWER

4

SINGLE
AND DUAL LANE
CAPABILITY

5

RADIO REMOTE
CONTROL
INCLUDED

6

PRE-ASSEMBLED
EASY TO INSTALL

7

MINIMUM
MAINTENANCE

8

HIGH
PENETRATION
POWER

10

SUITABLE FOR ANY
KIND OF CEREALS,
SEEDS, FLOURS
AND GRANULAR
MATERIAL

STORK SAMPLERS SINCE 1987

the fastest, easiest and safest way
to sample grain from an open
trailer, essential for large farms,
grain stores and mills.

GOOD REASONS TO BUY A STORK



ENGINEERING DEPARTMENT FOR CUSTOMIZED SOLUTIONS

Thanks to more than 30 years' experience and based on the continuing success of our STORK SAMPLERS, DV srl offers customised samplers to suit every customer's needs.

**AMONG THE CUSTOMISED
OPTIONS AVAILABLE, SAMPLERS
CAN BE DESIGNED TO BE:**



STORK "on the roof".

- | | | |
|--|-------------------------|---------------------------------|
| 1 | 2 | 3 |
| ROOF-MOUNTING
OR WALL-MOUNTING | ATEX
CONFORMING | EASILY MOVED
WITH A FORKLIFT |
| 1 | 2 | |
| PERMANENTLY
MOUNTABLE ON A
FLAT-BACK TRUCK | TRANSPORTED
BY LORRY | |

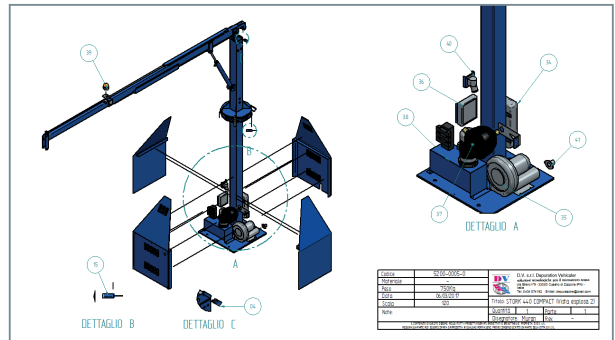

Solidedge 3D Design

STORK Mobile Sampling Station



Galvanized Sampler





DESIGN AND PRODUCTION MADE IN ITALY

**SINCE 1998 WE ARE
CERTIFIED ISO 9001**

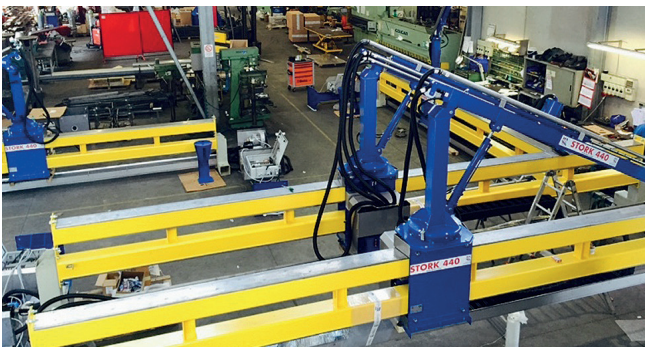

DV Production Departement

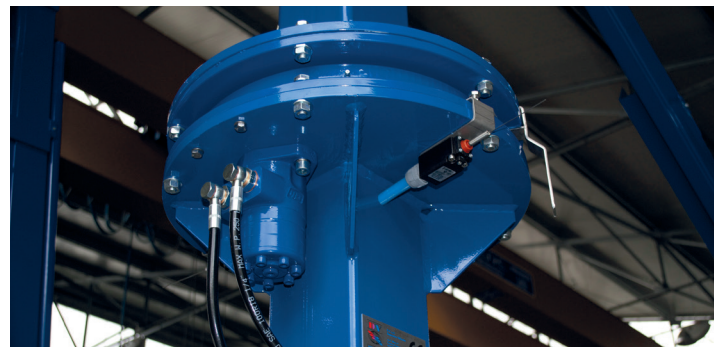

STORK 440 Rotary Bearing



DV Logistic Departement



STORK COMPACT ALL HYDRAULIC

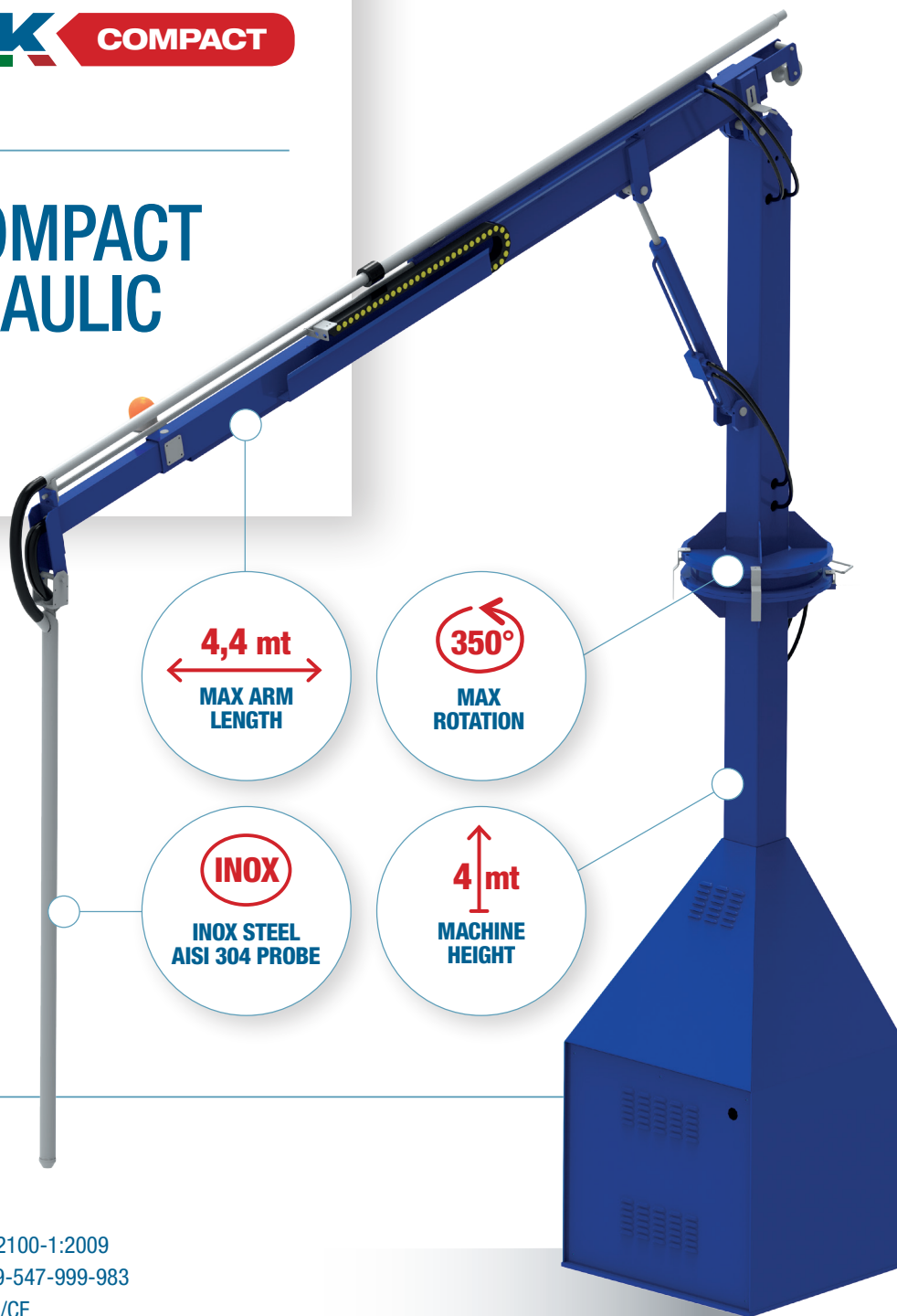

TECHNICAL FEATURES

POWER SUPPLY

400 VAC 3P + N + E 50 HZ

AIR BLOWER

THREE PHASE 2,2 KW
SIDE CHANNEL

HYDRAULIC UNIT 1,5 KW

SHIPPING WEIGHT 830 KG

MAX ROTATION 350°

EU CERTIFICATIONS

UNI EN ISO 24333-2010 / UNI EN ISO 12100-1:2009

UNI EN ISO 13857 - 13850 / UNI EN 349-547-999-983

2006/42/CE / 2006/95/CEE / 20447108/CE



INCLUDED



OPTIONAL



COMPACT

1

TELESCOPIC ARM

2

HIGH PENETRATION POWER, 8 NM

3

PRE ASSEMBLED EASY TO INSTALL

4

HOMOGENEOUS AND REPRESENTATIVE SAMPLE

5

ALL HYDRAULIC, MINIMUM MAINTENANCE

6

STRONG FRAME LONG TERM RESISTANCE

7

350° ROTATION DUAL LANE CAPABILITY

8

REACH THE BOTTOM OF THE TRAILER

DESIGNED FOR
9 MT
WHEIGHBRIDGES

DIMENSIONS

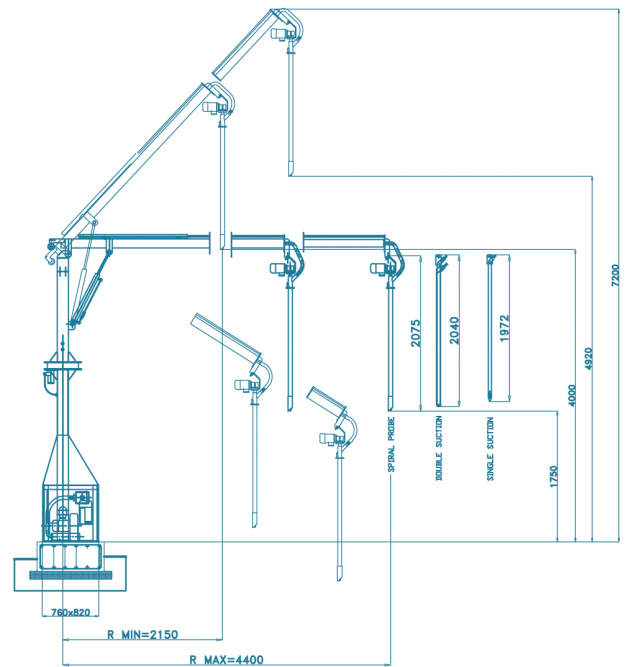

SAMPLING AREA

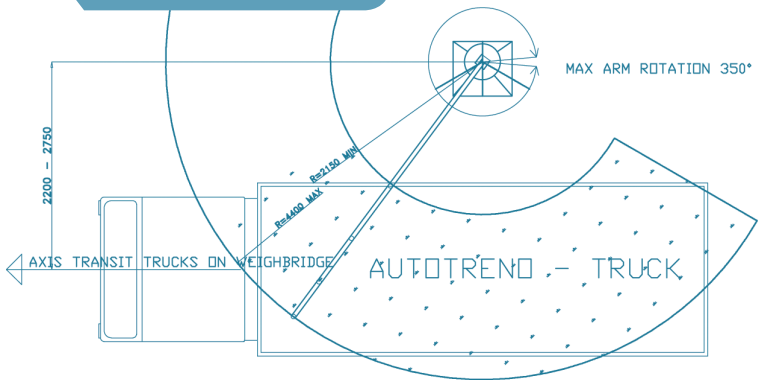

PROBES SINGLE SUCTION

STANDARD
2000 MM

OPTIONAL
2500 MM
2700 MM
3000 MM

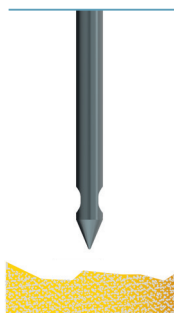

PROBES DOUBLE SUCTION

STANDARD
2000 MM

OPTIONAL
2300 MM
2500 MM
2700 MM



PROBES AUGER

STANDARD
2000 MM

OPTIONAL
2300 MM
2500 MM



ALL HYDRAULIC STORK RAIL

4,4 mt
MAX ARM LENGTH

350°
MAX ROTATION

TECHNICAL FEATURES

POWER SUPPLY
400 VAC 3P + N + E 50 HZ

AIR BLOWER
THREE PHASE 2,2 KW
SIDE CHANNEL

HYDRAULIC UNIT 1,5 KW

SHIPPING WEIGHT 1750 KG

MAX ROTATION 350°

INOX
INOX STEEL
AISI 304 PROBE

5,1 mt
MACHINE HEIGHT

EU CERTIFICATIONS

UNI EN ISO 24333-2010 / UNI EN ISO 12100-1:2009
UNI EN ISO 13857 - 13850 / UNI EN 349-547-999-983
2006/42/CE / 2006/95/CEE / 20447108/CE



INCLUDED



OPTIONAL



RAIL

- 1 DESIGNED FOR 18 MT WEIGHBRIDGES
- 2 TELESCOPIC ARM
- 3 PRE ASSEMBLED EASY TO INSTALL
- 4 HIGH PENETRATION POWER, 8 NM
- 5 STRONG FRAME LONG TERM RESISTANCE
- 6 350° ROTATION DUAL LANE CAPABILITY
- 7 FOR DOUBLE TRAILERS TRUCK
- 8 ALL HYDRAULIC MINIMUM MAINTENANCE
- 9 HOMOGENEOUS AND REPRESENTATIVE SAMPLE

DESIGNED FOR
18 MT
WEIGHBRIDGES

DIMENSIONS

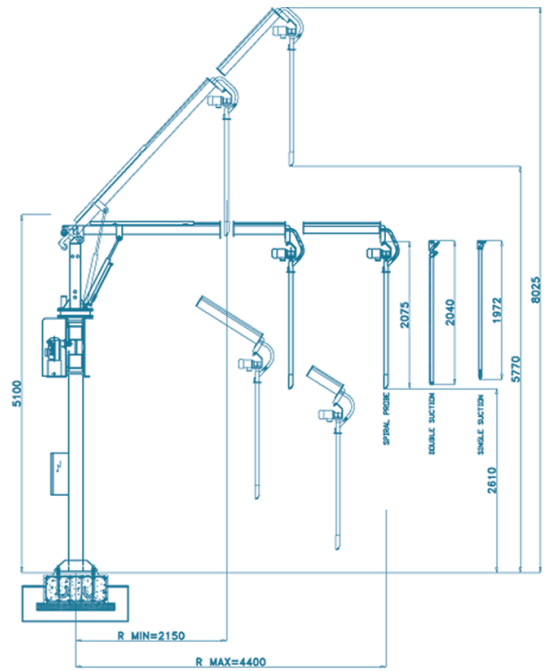

SAMPLING AREA

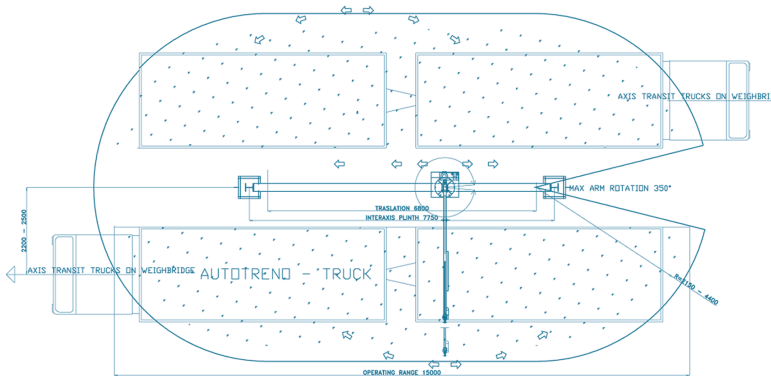

PROBES SINGLE SUCTION

STANDARD
2000 MM

OPTIONAL
2500 MM
2700 MM
3000 MM



PROBES DOUBLE SUCTION

STANDARD
2000 MM

OPTIONAL
2300 MM
2500 MM
2700 MM



PROBES AUGER

STANDARD
2000 MM

OPTIONAL
2300 MM
2500 MM



COMPACT AND RAIL

HYBRID SERIES

**STORK HYBRID SAMPLERS
5 SAMPLES IN 60 SECONDS WITH
SMOOTH AND FAST MOVEMENTS**

EU CERTIFICATIONS

UNI EN ISO 24333-2010 / UNI EN ISO 12100-1:2009
UNI EN ISO 13857 - 13850 / UNI EN 349-547-999-983
2006/42/CE / 2006/95/CEE / 20447108/CE

60"

FIVE SAMPLES



FAST
OPERATIONS

TECHNICAL FEATURES

POWER SUPPLY
400 VAC 3P + N + E 50 HZ

AIR BLOWER
THREE PHASE 2,2 KW
SIDE CHANNEL

HYDRAULIC UNIT 1,5 KW

MAX ROTATION 350°

SHIPPING WEIGHT
COMPACT HYBRID 830 KG
RAIL HYBRID 1750 KG

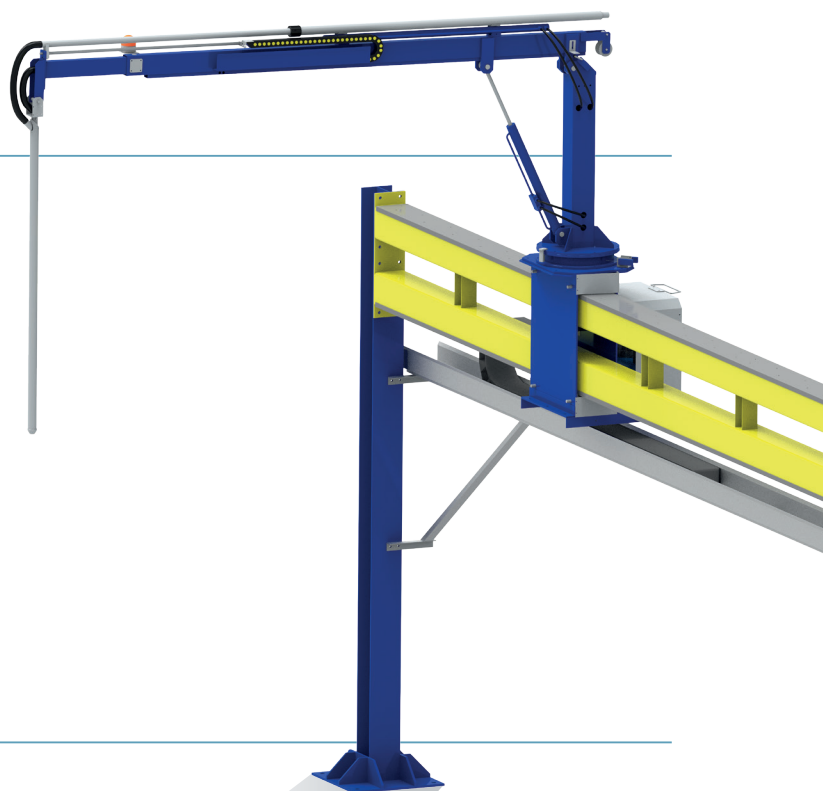
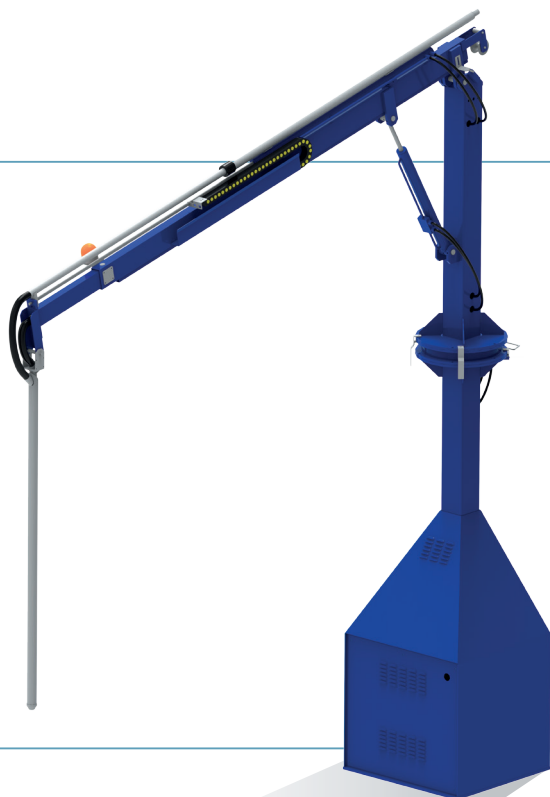

INCLUDED



WIRELESS CONTROL



SUCTION TURBINE
2,2 KW

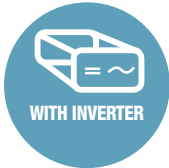

WITH INVERTER



OPTIONAL



VIDEO CAMERA SYSTEM

COMPACTHYBRID

RAILHYBRID

1

FAST OPERATIONS

2

5 SAMPLES IN 60"

3

ENERGY SAVING

4

HOMOGENEOUS AND REPRESENTATIVE SAMPLE

5

ALL HYDRAULIC,
MINIMUM MAINTENANCE

6

STRONG FRAME
LONG TERM RESISTANCE

7

HIGH PENETRATION
POWER

8

350° ROTATION
DUAL LANE
CAPABILITY

HYBRID SERIE / INVERTER / PLC

Thanks to an inverter installed in the electrical cabinet STORK HYBRID samplers are able to take 5 samples in 60 seconds with smooth and fast movements, keeping all the good technical features of the hydraulic series.

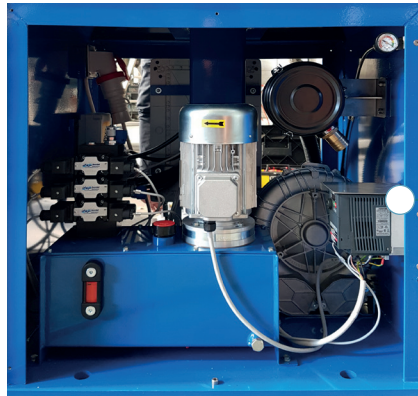

PROBES SINGLE SUCTION

STANDARD

2000 MM

OPTIONAL

2500 MM

2700 MM

3000 MM



PROBES DOUBLE SUCTION

STANDARD

2000 MM

OPTIONAL

2300 MM

2500 MM

2700 MM



PROBES AUGER

STANDARD

2000 MM

OPTIONAL

2300 MM

2500 MM



STORK PRO ALL ELECTRIC



EU CERTIFICATIONS

UNI EN ISO 24333-2010 / UNI EN ISO 12100-1:2009
UNI EN ISO 13857 - 13850 / UNI EN 349-547-999-983
2006/42/CE / 2006/95/CEE / 20447108/CE



TECHNICAL FEATURES

POWER SUPPLY
400 VAC 3P + N + E 50 HZ

AIR BLOWER
THREE PHASE 2,2 KW
SIDE CHANNEL

INCLUDED

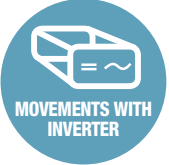

PRO

- 1 ALL ELECTRIC
- 2 HIGH RESOLUTION VIDOCAMERA
- 3 HIGH SPEED OPERATIONS
- 4 6 METERS MODULES
- 5 MOVEMENTS WITH INVERTER
- 6 VERTICAL PROBE
- 7 DESIGNED FOR FULL AUTOMATIC SAMPLING
- 8 SOFTWARE DEDICATED (WINDOWS 8 OR MORE) OPTIONAL

SPECIAL DESIGN FOR RAIL WAGONS TANK TRUCKS

DIMENSIONS

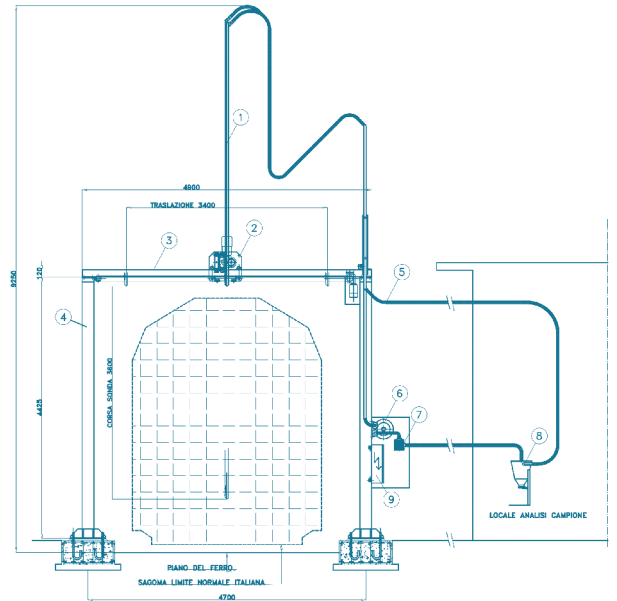

OTHER VERSION

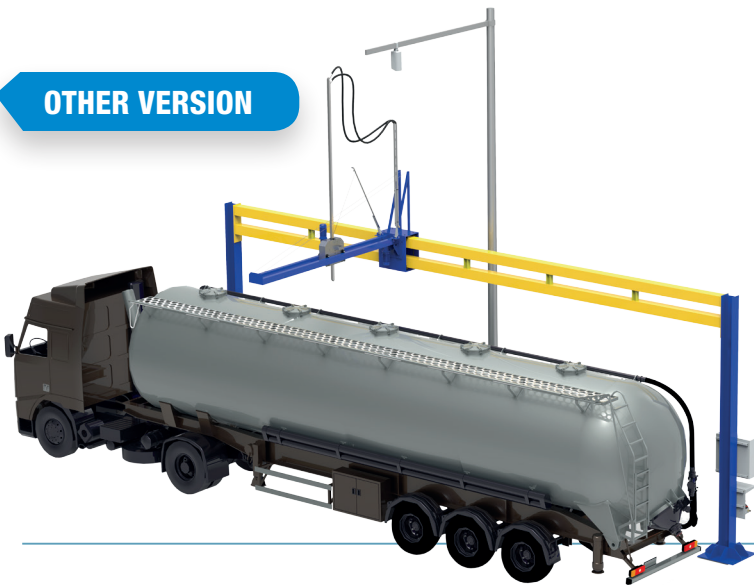

COMPACT AND RAIL

AUTOMATIC SERIES

**PROGRAM ON YOUR
 WORKSTATION UP TO SEVEN
 SAMPLING POINTS**



- 1**
 FIRST POSITION IS CHOSEN MANUALLY
- 2**
 MULTIPLE SAMPLES WITH ONE BUTTON
- 3**
 3 SETTABLE DISTANCES
- 4**
 SELECT DIRECTION (LEFT TO RIGHT) (RIGHT TO LEFT)
- 5**
 FROM 2 TO 7 SAMPLING POINT
- 6**
 PANEL PC TOUCH SCREEN (ITA-ENG-RUS)

SAMPLING EXAMPLES

2 / 3 SAMPLING POINTS



4 SAMPLING POINTS



MULTIPLE SAMPLING POINTS





STORK PRO

AUTOMATIC SERIES

THE FIRST FULL AUTOMATIC SAMPLING SYSTEM IN THE WORLD

STORK FULL AUTOMATIC SAMPLING SYSTEM

Together with the development of the STORK PRO we DESIGNED a dedicated software that works with a high resolution videocamera that allows the operator to choose several sampling points and start the sampling cycle with one button. The sampler can work in automatic or manual mode giving to the client a totally customized and freedom operations.



- 1** COMPUTER INCLUDED IN THE SUPPLY
- 2** HIGH RESOLUTION VIDOCAMERA
- 3** SAVE SAMPLING PATTERNS
- 4** REDUCE HUMAN INPUT
- 5** REPEATABLE RANDOM SAMPLING
- 6** SELECT SAMPLING POINT ON THE SCREEN
- 7** DEDICATED SOFTWARE (WINDOWS 8 OR MORE)

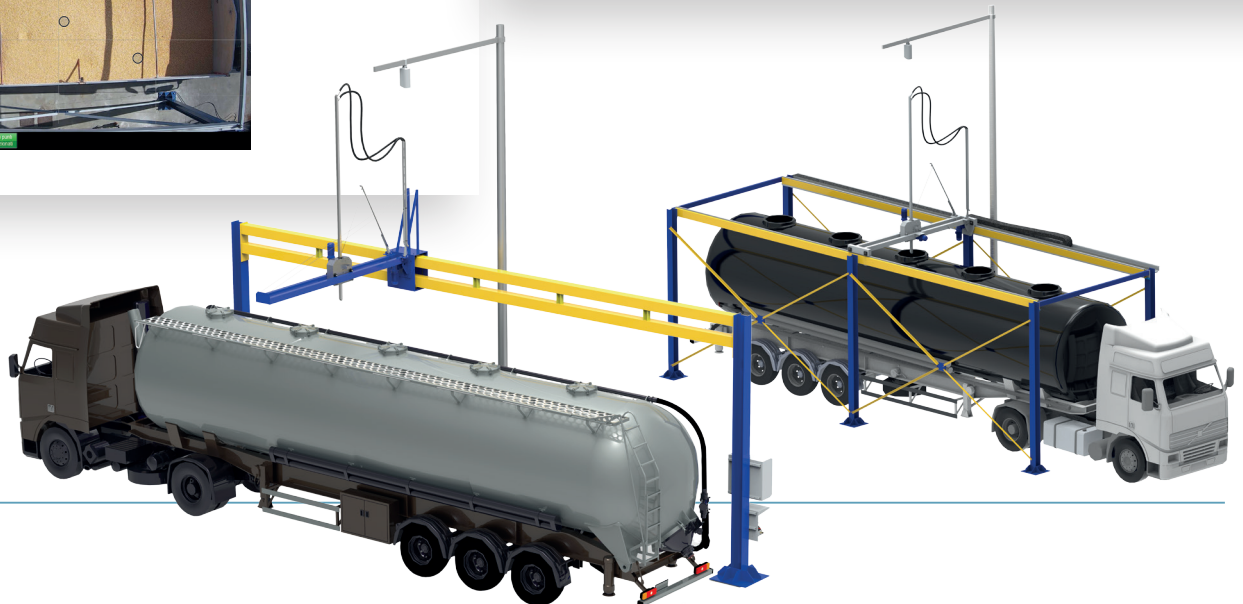

SAMPLES MORE QUICK AND EASY WITH ORIGINAL ACCESSORIES

STORK FLUSH BACK SYSTEM



TECHNICAL FEATURES

- 1 Discharge hopper
- 2 Return hopper
- 3 Remote control
- 4 Suction unit
- 5 Motorized valve
- 6 Motor of hydraulic unit

1

SEND THE EXCEEDING MATERIAL BACK TO THE TRUCK

2

SIMPLE TO USE, ONE BUTTON OPERATION.

3

USE THE SAME BLOWER

*

Available also an independent system to send the product to a basin outside the laboratory.

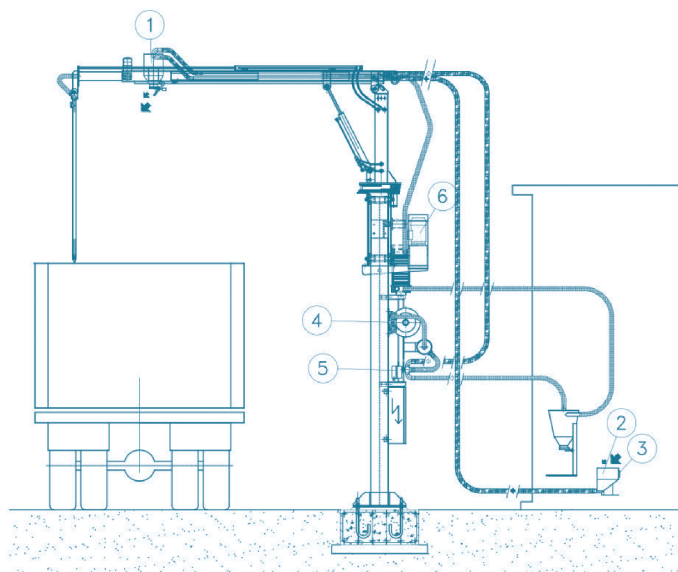

TECHNICAL FEATURES

1

DIVIDING SAMPLES OF GRAIN, SEED AND OTHER GRANULAR PRODUCTS.

2

DIVIDE 4 KG OF SAMPLE INTO 2 SAMPLES OF 1 KG EACH

3

ADJUSTABLE BY HANDLE

*

Integrated with Stork flush back system.

STORK DIVIDER



TECHNICAL FEATURES

1

STORK CONVERTIBLE KIT ALLOWS TO USE ALL THE THREE TYPE OF PROBES (SINGLE SUCTION – DOUBLE SUCTION – AUGER) ON ONE SAMPLER

2

THE SYSTEM IS DESIGNED IN ORDER TO CHANGE THE PROBE QUICKLY AND EASILY

*

Available for stork compact and rail.

STORK CONVERTIBLE KIT



TECHNICAL FEATURES

1

STORK VIDEOCAMERA SYSTEM IS COMPOSED BY: All in one day and night colour camera, 3,6 mm fixed lens, 800 tvl resolution, 960 H, case waterproof IP 66, 23 infrared leds with a range of 20 meters.

2

VIDEOCAMERA IS MOUNTED ON THE PROBE WITH A STAINLESS STEEL SUPPORT

3

TV LED 20" INCLUDED.

STORK VIDEOCAMERA SYSTEM



STORK

SALES NETWORK

STORK AROUND THE WORLD...

Stork samplers are present in more than 30 countries around the world with a solid and qualified distributors' network. Our distributors are able issue commercial offers, install the samplers, and provide technical services...



EUROPA

- ▶ Belarus
- ▶ Bulgaria
- ▶ Croatia
- ▶ Denmark
- ▶ France
- ▶ Greece
- ▶ Italy
- ▶ Latvia
- ▶ Lithuania
- ▶ Macedonia
- ▶ Moldova
- ▶ Montenegro
- ▶ Norway
- ▶ Poland
- ▶ Portugal
- ▶ United Kingdom
- ▶ Czech Republic
- ▶ Romania
- ▶ Russia
- ▶ Serbia
- ▶ Slovakia
- ▶ Slovenia
- ▶ Spain
- ▶ Sweden
- ▶ Ukraine
- ▶ Hungary

ASIA

- ▶ Kazakhstan
- ▶ Thailand
- ▶ Uzbekistan
- ▶ Cambodia
- ▶ Vietnam

SOUTH AMERICA

- ▶ Chile

OCEANIA

- ▶ Australia
- ▶ New Zealand

AFRICA

- ▶ South Africa

STORK LOCATION

**DV HEADQUARTER IS LOCATED
IN PORDENONE, FRIULI VENEZIA
GIULIA A NORTHEASTERN
REGION OF ITALY.**



FRIULI VENEZIA GIULIA

With its triple-barrelled moniker, Friuli Venezia Giulia's multifaceted nature should come as no surprise. Cultural complexity is cherished in this small, little-visited region, tucked away on Italy's far northeastern borders with Austria and Slovenia. Friuli Venezia Giulia's landscapes offer profound contrasts too, with the foreboding, perpetually snowy Giulie and Carnic Alps in the north, idyllic grapevine-filled plains in the centre, the south's beaches, Venetian-like lagoons and the curious, craggy karst that encircles Trieste. While there's an amazing reserve of often uncrowded historical sights, from Roman ruins to Austro-Hungarian palaces, this is also a fine destination for simply kicking back with the locals, tasting the region's world-famous wines and discovering a culinary heritage that will broaden your notions of the Italian table. Serene, intriguing Trieste and friendly, feisty Udine make for great city time – they're so easy and welcoming you'll soon feel as if you're Friulian, Venetian or Giulian too.

www.lonelyplanet.com

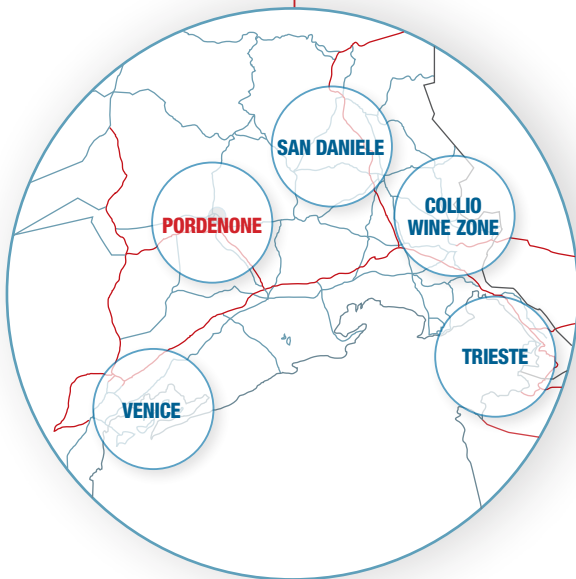

VENICE > 90 KM



TRIESTE > 105 KM



COLLIO ZONE > 90 KM





D.V. srl
Depuration Vehiculer

Via E.Ellero n.9 33080 Cusano di Zoppola (Pn) Italy
Tel. 0039_0434 574192 r.a. Fax 0039_0434 977070
info@dvsrl.com www.dvsrl.com



www.grainsamplers.com



STORK
sampling solutions



www.grainsamplers.com



DV *SRL*

Soluzioni Tecnologiche
per l'Industria Agroalimentare

www.dvsrl.com